

First testing of horse-drawn roller-cutter for green-manure crops management in Croatia

Ranko Gantner¹, Paul Schmit², Zvonimir Steiner¹, Domagoj Zimmer¹, Anamarija Banaj¹, Igor DelVecchio², Vesna Gantner¹

¹ Faculty of Agrobiotechnical Sciences Osijek, Josip Juraj Strossmayer University of Osijek, Vladimira Preloga 1, HR-31000 Osijek, Croatia

² Schaff mat Päerd asbl., 27, rue de Brouch, L-7481 Tuntange, Luxembourg

³ Croatian Federation of Heavy Draft Horse Breeders Association. Jelengradska 13, HR-44317 Popovača, Croatia

Abstract

Green manuring (GM) for raising the soil fertility becomes increasingly important due to environmental and other sustainability issues. However, GM is unavoidably associated with additional agrotechnical operations and energy consumption required for establishment of GM crops and their termination or incorporation of a GM herbage into soil, depending on the soil tillage system. Horse powered agriculture could be an option to decrease or avoid the consumption of fossil energy, as well as CO₂ emissions from powering the cultivation of arable crops. However, some operations in GM management might be challenging by using solely the living horse power, namely the chopping of GM's herbage before its incorporation into soil. An entirely CAD-designed retroinnovation developed in Schaff mat Paerd asbl. of Luxembourg has given a horse-drawn alternative to tractor powered choppers and mulchers. The horse-drawn roller-cutter showed a good performance on crimson clover (*Trifolium incarnatum* L.) GM crop at the experimental site near Požega. However, the broad acceptance of horse-powered farming might be challenging due to decrease of human labor efficiency when compared to modern tractorized farming. Raising the consciousness about sustainability issues and need for improved resilience to changing climate, as well as personal inner transformation of people might be needed to improve the image of such a labor-intensive agriculture.

Key words: green manuring, fossil energy consumption, sustainability, CO₂ emissions, low-input farming, inner transformation

Introduction

Green manuring (GM) for raising the soil fertility becomes increasingly important due to environmental and other sustainability issues. Namely, predominant reliance on the synthetic nitrogen (N) mineral fertilizers for achieving the high crop yields since the Green revolution has been associated with many detrimental consequences. According to Basosi et al. (2014), mineral nitrogen fertilization represents one of the main agricultural practices with a high emission of pollutants into the atmosphere, soil and water. De Vries (2021) indicates the need to reduce the N emissions, both from agriculture and from traffic and industrial sources. Moreover, in the times of prospective depletion of fossil fuels that are necessary for powering the synthesis of mineral nitrogen fertilizers, and climate policies that push the industries and societies to minimize the CO₂ and N₂O emissions, and to decrease the reliance on fossil energy resources, green manuring may become one of the core options to maintain or rise the soil fertility and crop yields. However, GM is unavoidably associated with additional agrotechnical operations and energy consumption required for establishment of GM crops and their termination or incorporation of a GM herbage into soil, depending on the soil tillage system (Ambrušec et al., 2021; Wu et al., 2011). Inspired by the need to reduce the consumption of fossil fuels, Ambrušec et al. (2021) have proposed the use of animal work for powering the agrotechnical operations by smallholdings and small-scale farms. This is in line with the principles of low-input farming (Parr et al., 1990; cit. Poux, 2007) where should be optimized the farmers' reliance on the on-farm produced inputs, while closing the cycles of nutrients and energy, and minimizing the adverse environmental impacts.

According to the author's previous experience, in agronomy where the main crop is seeded into a conventionally prepared seedbed (i.e. into a fine structured bare ground), green manuring can be challenging if there is present a huge and tall GM herbage on the soil surface. The problem rises when there are used small plows, like horse drawn plows, that can hardly completely cover the tall herbage with the soil due to the shallow plowing depth. In a large-scale arable farming there are being used tractor-powered choppers or mulchers with working width of 2 to 3 m and great efficiency. In small-scale farming and small-plot fields there are often being used small mulchers. In the previous experiments of Ambrušec et al. (2021), the GM herbage was chopped by a small gasoline-powered mulcher (Honda F-620 Y + MIO Standard mulcher) with aim to ease the plowing herbage under, to speed up the

¹ ranko.gantner@fazos.hr

herbage decomposition, and release of plant nutrients from herbage into soil (Photo 1). However, if there is an ambition to completely avoid the consumption of fossil fuels, this requires an alternative implement to chop the herbage before plowing it under. Recently, the Schaff mat Paerd asbl. of Luxembourg has designed a prototype of roller-cutter aimed for chopping the herbage mass for green manuring (photos 2 and 3). This roller-cutter is intended for small farms that employ animal power for agricultural operations. Therefore, it is a light-weight implement with cutting blades driven by rolling action of oval knife-fitted stainless steel rings around a rubber roller, rolled over the soil surface. Aim of this preliminary research was to obtain a quick appraisal of the roller-cutter's performance in chopping the green manure's herbage for subsequent plowing it under and seedbed preparation.



Photo 1. Gasoline-powered mini-tractor Honda F-620 Y coupled with MIO Standard mulcher used to chop the crimson clover herbage in previous researches



Photo 2. Blades on steel rings over the rubber drum on horse-powered roller-cutter for chopping the crimson clover herbage in this research (designed by Schaff mat Paerd asbl., Luxembourg)



Photo 3. Double traction shafts in front of the roller-cutter for hitching a single horse

Material and methods

The investigated implement was the SmP Kombi-Roll Concept 3.0, the 3rd generation roller-cutter of the Schaff mat Paerd asbl. of Luxembourg. It consists of an inner rubber roller vulcanized on a steel drum that carries 5 stainless-steel floating rings that copy the terrain and bear 12 stainless-steel chopping blades on each ring (Figure 1). The inner roller is coupled to a frame by two greasable ball bearings. Frame is equipped with two pneumatic wheels for the transport and a screw handle for lifting the roller together with the frame. Frame is coupled with a double traction shafts adapted to hitch a single horse. Total weight of the implement is 200 kg.

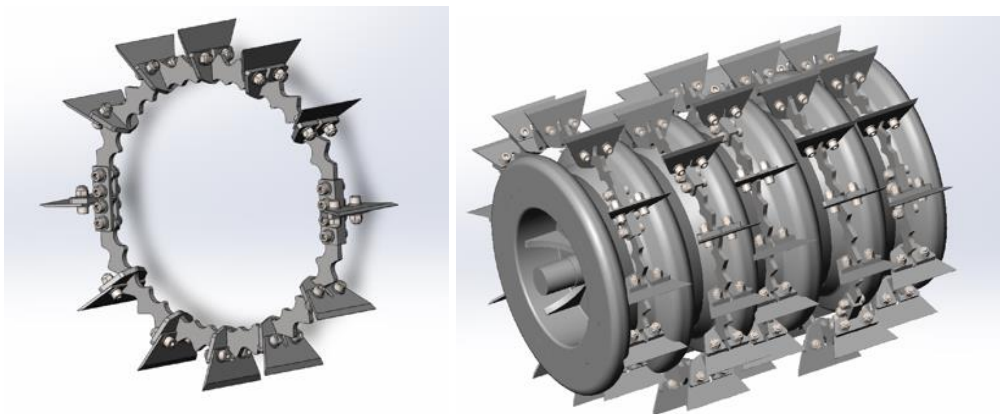

Figure 1: floating stainless-steel ring (left), and rings mounted on rubber roller (right)

Testing was performed on a small field near Požega town (arable parcel of 3000 m² in total, but rolling was done on less than a half of the area), on 22nd April 2023, on a crimson clover (*Trifolium incarnatum* L.) crop grown for green manuring, with some volunteering oats. Crimson clover was seeded in early September 2022. At places where the chop length was measured, before the pass of the implement the crimson clover plant height was between 38 and 43 cm (Photo 4), and the clover's stand and canopy were dense. Crimson clover was in a late vegetative stage with soft stems. The roller-cutter was drawn by the Croatian Heavy Draft Horse mare (Photo 5), approximate bodyweight of 650 kg.



Photo 4. Intact herbage mass of the crimson clover before chopping



Photo 4. Croatian Heavy Draft Horse mare with the roller-cutter hitched

Results and discussion

Testing has proven that the crimson clover can be efficiently laid down and chopped in just a single pass with the horse-drawn roller-cutter, with no use of fossil fuel. The investigated roller-cutter obviously needed just a little of energy for its operation. Namely, the mare which pulled the implement didn't show signs of fatigue during the work, thus indicating that there were low traction forces required. Effectivity of the roller-cutter was quite good. All the present herbage of crimson clover was cut and laid down, with no intact plants remained, thus enabling for easy plowing-under the herbage. Chop lengths after a single pass of the implement were from 17 to 37 cm (Photo 6).



Photo 6. Chopped crimson clover herbage mass after a single pass of the roller-cutter

Working width was 60 cm, working speed about 4,5 km/h and time required for a turn was about 10 s. Under the assumption that small farmers' plots in the north-eastern Croatia have a length of 400 m, there would be theoretically required about 0,09 hours or 5.4 minutes for a single pass. With the anticipated rest of a horse and man, the time required for a single pass would be about 6 minutes. The laid and chopped area of a single pass would be equal to 240 m² or 0,024 ha per pass. Under the assumptions that the time required for harnessing, hitching and arrival to a field would be half an hour, and the same for the return back home, then in the 8-hours working day there would remain 7 hours available for the field work. Under the assumption that a team of single horse and man can work 7 hours per day in a field, the work efficiency might be up to 70 passes 400 m long. i.e. 16800 m² or 1.68 ha per working day.

The above presented working efficiency is theoretical and therefore should be tested in practical farming where the eventual fatigue of horse and man could appear due to greater working area than in this preliminary trial.

Although the draft force was obviously low, for proving this there would be required measurements by field dynamometer (Schmit et al., 2022). In order to achieve a high-quality appraisal of the tested implement, there would be required to continue the testing on various GM herbage differing in maturity, plant species, plant height and stem rigidity.

Despite the proven feasibility of horse-drawn agriculture to cope with challenges associated with green manuring (at least with soft-stemmed crimson clover), the horse traction may not face the broad acceptance by the agricultural experts and general public, mainly due to very low efficiency of human labor. Namely, a single tractor-operator and 75 kW tractor equipped with 3.2 m working width mulcher can do 1.2 ha/h, or 9.6 hectares in one working shift (8 hours), what is 5.7 times more than the projection for the horse-drawn variant. Modern people could dislike the dramatical decrease of human labor efficiency, or the related increase of the need for human labor in the horse-drawn agriculture, not only because of lower efficiency, but also due to it is less convenient than sitting in a tractor cabin or doing office-based jobs and jobs associated with soft skills. Rising the consciousness of the sustainability issues and need for climatic resilience, as well as the personal inner transformation of people might be needed to make the horse-drawn agriculture appears more attractive. The greater need for human labor in agriculture might induce the return of people to rural areas and countryside thus relieving the cities and lessening the urban waste generation. Namely, urban waste generation per capita is always greater than of rural people (Gómez-Sanabria et al., 2022), and rural waste is more easily recycled or reused (Bernardes and Günther, 2014).

Conclusion

Newly designed roller-cutter SmP Kombi-Roll Concept 3.0 has shown an excellent performance in laying down and chopping the crimson clover herbage in a late vegetative stage when intended for green manuring. Working speed was about 4.5 km/h and working width 0.60 m, thus enabling the theoretically projected work efficiency of 1.68 ha per 8-hours working day, with included short rests for man and horse, and 1 hour for hitching, getting to a field, getting back and hitching-off. The projected work efficiency is much lesser than of a modern 75 kW (100 hp) tractor equipped with 3,2 m working width mulcher, that can do 1,2 ha/h, or 9,6 hectares in one working shift (8 hours), which is 5.7 times more than the projection for the horse-drawn variant. Due to much lesser effectiveness of human labor and

poorer convenience of a worker, there is not anticipated a broad acceptance of horse-drawn technology nowadays, except in small organic farms and marginal areas of agriculture, like in mountains. However, consciousness about sustainability issues, and need for climate resilience might favour the acceptance even in major agricultural regions. For a better acceptance there is needed education of stakeholders in food chain, as well as the personal inner transformation (Woiwode et al., 2021) of people and farmers.

Acknowledgements

Research and dissemination were supported by the Fund for Bilateral Relations within the Financial Mechanism of the European Economic Area and Norwegian Financial Mechanism for the period 2014-2021 (Grant number: 04-UBS-U-0031/23-14).

References

1. Ambrušec, Lj., Gantner, R., Herman, G., Gantner, V., Bošnjak, K., Bukvić, G. (2021.): Green manuring with crimson clover as an alternative to mineral fertilization in maize production: one season results from northeast Croatia. *Hollistic Approach to Environment* 11(2021)4: 102-108.
2. Basosi, R., Spinelli, S., Fierro, A., Jez, S. (2014): Mineral Nitrogen Fertilizers: Environmental Impact of Production and Use. In book: *Fertilizers: Components, Uses in Agriculture and Environmental Impacts* (pp.3-43) Edition: First. Chapter: 1. Publisher: NOVA Science Publishers. Editors: Fernando Lòpez-Valdez, Fabiàn Fernàndez Luqueno.
3. Bernardes, C., Günther, W.M.R. (2014): Generation of Domestic Solid Waste in Rural Areas: Case Study of Remote Communities in the Brazilian Amazon. *Human Ecology* 42, 617–623 (2014). <https://doi.org/10.1007/s10745-014-9679-z>
4. De Vries, W. (2021): Impacts of nitrogen emissions on ecosystems and human health: A mini review. *Current Opinion in Environmental Science & Health*. Volume 21, June 2021, 100249.
5. Gómez-Sanabria, A., Kiesewetter, G., Klimont, Z., Schoepp1, W., Haberl, H. (2022): Potential for future reductions of global GHG and air pollutants from circular waste management systems. *Nature Communications* (2922)13:106. | <https://doi.org/10.1038/s41467-021-27624-7> | www.nature.com/naturecommunications
6. Parr, J. F., Papendick, R. I., Youngberg, I. G., Meyer, R. E. (1990): Sustainable Agriculture in the United States. In *Sustainable Agricultural Systems*, ed. by Clive A., Edwards, et al. Soil and Water Conservation Society, Ankeny, Iowa.
7. Poux, X. (2007): Low input farming systems in Europe: What is at stake? In: *Low Input Farming Systems: an Opportunity to Develop Sustainable Agriculture*. Proceedings of the JRC Summer University. Ranco, 2-5 July 2007. Editors: Katarzyna Biala, Jean-Michel Terres Philippe Pointereau, Maria Luisa Paracchini. European Commission Joint Research Centre, Institute for Environment and Sustainability. Luxembourg. Pages: 1-11.

8. Schmit, P., Gantner, R., Neubauer, A., Garre, A. (2022): Evaluating horse drawn tillage technology through digital data logging. Book of abstracts of the ISDTA 2022 1st International Symposium on Digital Technologies in Agriculture and DIGITAGRA 2022 1st Satellite Workshop – Digital Agriculture in Rural Area. Faculty of Agrobiotechnical Sciences Osijek. Osijek. Page nr. 5.
9. Woiwode, C., Schöpke, N., Bina, O., Veciana, S., Kunze, I., Parodi, O., Schweizer-Ries, P. Wamsler, C. (2021): Inner transformation to sustainability as a deep leverage point: fostering new avenues for change through dialogue and reflection. *Sustainability Science* (2021) 16:841–858
10. Wu, J.Y., Martinov, M., Sardo, V.I. (2011). Human Labour and Green Manure, Two Overlooked Factors for Energy Analysis in Agriculture. In: Lichtfouse, E. (eds) *Genetics, Biofuels and Local Farming Systems. Sustainable Agriculture Reviews*, vol 7. Springer, Dordrecht. https://doi.org/10.1007/978-94-007-1521-9_7

Prvo testiranje valjka-sjekača na konjsku vuču za zelenu gnojidbu u Hrvatskoj

Ranko Gantner¹, Paul Schmit², Zvonimir Steiner¹, Domagoj Zimmer¹, Anamarija Banaj¹, Igor DelVecchio², Vesna Gantner¹

¹ *Fakultet Agrobiotehničkih znanosti Osijek, Sveučilište Josipa Juraja Strossmayera u Osijeku, Osijek, Hrvatska*

² *Schaff mat Pæerd asbl., 27, rue de Brouch, L-7481 Tuntange, Luxembourg*

³ *Središnji savez udruga uzgajivača hrvatskog hladnokrvnjaka, Popovača, Hrvatska*

Sažetak

Zelena gnojidba (ZG) za podizanje plodnosti tla postaje sve važnija zbog ekoloških i drugih pitanja održivosti. Kakogod, ZG je neizbježno povezana s dodatnim agrotehničkim zahvatima i utroškom energije potrebnim za uzgoj ZG usjeva i njihovu terminaciju ili inkorporaciju u tlo, ovisno o sustavu obrade tla. Poljoprivreda na konjski pogon mogla bi biti opcija za smanjenje ili izbjegavanje potrošnje fosilne energije. Međutim, neke radnje u provođenju zelene gnojidbe mogu biti teže izvedive korištenjem samo žive konjske snage. Naime, usitnjavanje zelene mase biljaka prije unošenja u tlo sada se radi traktorskim malčerima, a alternativa bez utroška goriva do sada nije bila poznata. Retroinovacija napravljena u Schaff mat Paerd asbl. iz Luksemburga dala je alternativu traktorskim sjeckalicama i malčerima. Alternativni valjak-sjekač na konjsku vuču pokazao je dobre rezultate na usjevu inkarnatske djeteline na pokusnom mjestu kod Požege. Ipak, prihvaćanje poljoprivrede na konjski pogon može biti problematično zbog smanjenja učinkovitosti ljudskog rada u usporedbi s modernom traktoriziranim poljoprivredom. Podizanje svijesti o pitanjima održivosti i osobna unutarnja transformacija ljudi možda će biti potrebna kako bi se poboljšala slika takve radno intenzivne poljoprivrede.

Ključne riječi: sideracija, potrošnja fosilnih goriva, održivost, emisija CO₂, poljoprivreda s malim ulaganjima, unutrašnja transformacija